

ComfortStar®

Air Conditioning and Heating

SPECIFICATION sheet

HD2



Three-speed Air Handler

Standard features:

- Multi-position: upflow and horizontal right. Easily field converted to downflow and horizontal left
- Suitable for use with R22 or new R410a
- Cooling only and suitable for heat pump application
- Direct drive, 3-speed PSC motor
- Transformer, fan relay and time delay included
- Fuse protected
- Easy slide out motor housing
- UV light opening
- Built-in filter rack for 1" filter (filter not included)
- Pre-installed piston
- Factory installed door seal to achieve 2% or less leakage rate of 1.0" external duct static pressure, which meets Florida building code
- Sweat connection
- ARI certified & ETL listed

Cabinet features:

- Galvanized steel with gray powder paint on all panels
- Fully insulated cabinet
- Primary and secondary drain connections (3/4" NPT)
- Power supply entry at side and top, low-voltage entry at top

Optional Accessories:

- 5kw to 20kw electric heat kits available for field installation
- Permanent washable air filter

1-1/2 to 5 Ton
Multi-position



HD2



11 Models

HD2-18 HD2-42
HD2-24 HD2-43
HD2-25 HD2-48
HD2-30 HD2-60
HD2-31 HD2-61
HD2-36



1-1/2 to 5 Ton
Multi-position
Three-speed Air Handler

General Terms of Limited Warranty

ComfortStar USA warrants that our products conform to the manufacturer specifications and will be free of defects in material and workmanship under normal use and maintenance.

For complete details of the limited warranty, including applicable terms and conditions. Please visit our website or contact our offices.



Model Number Identification

<u>HD</u>	<u>2</u>	<u>18</u>
Air Handler	second generation	capacity 18,000 (Btu/h)

Before proceeding with installation, refer to installation instructions packaged with each model. Please comply with all federal, state, provincial, and local codes, regulations and practices.

Dimensions

ELECTRICAL CONNECTIONS
MAY EXIT ON TOP OR EITHER SIDE

SUPPLY AIR

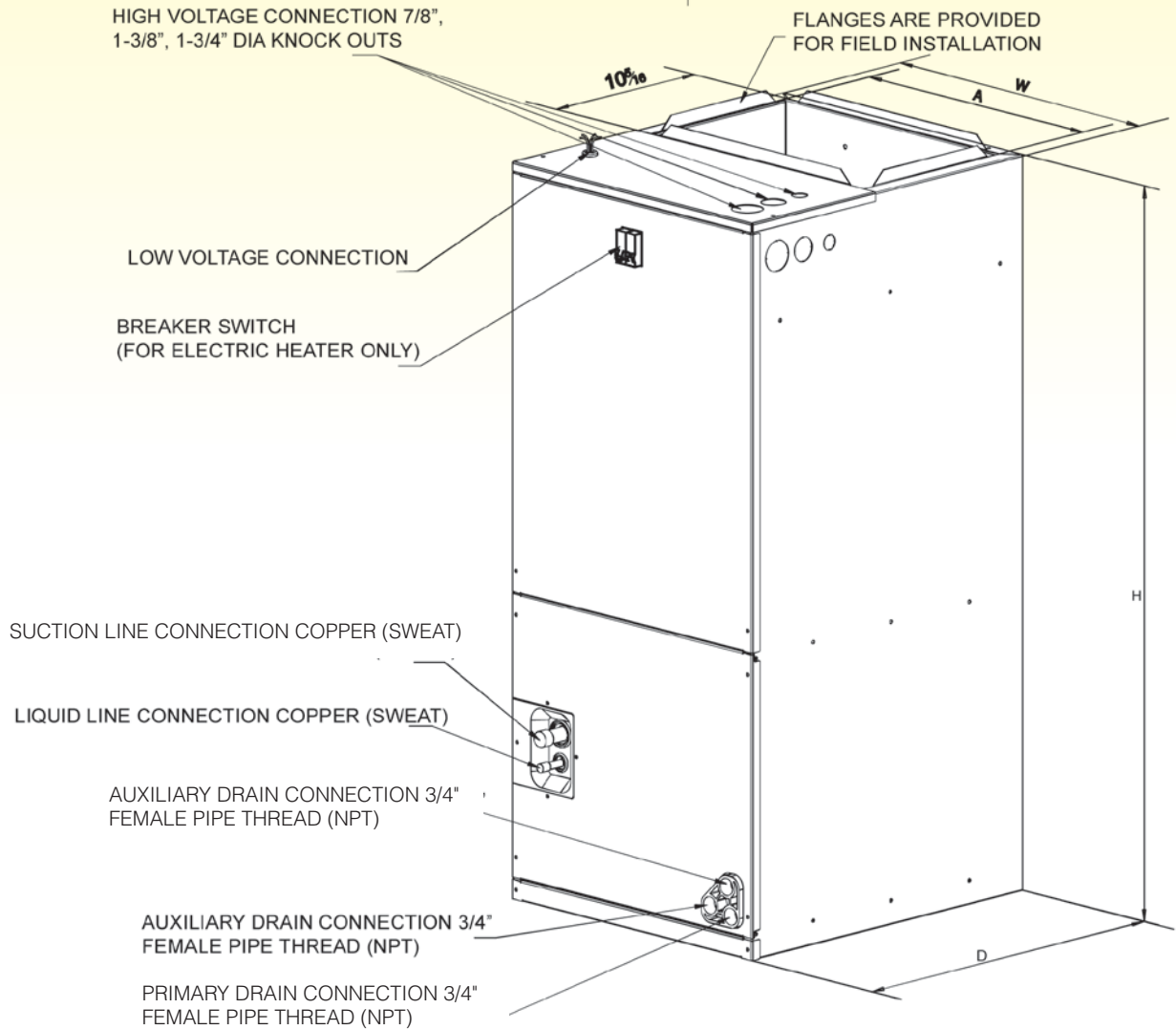

Dimensional Data

MODEL SIZE	Dimensions inch (mm)				Unit Weight/Shipping weight (lbs.) (kg.)
	Unit Height "H" in (mm)	Unit Width "W" in (mm)	Unit Depth "D" in (mm)	Supply Duct "A" in (mm)	
HD2-18	41-3/8" (1050)	18-1/8" (460)	20-1/2" (520)	16" (406)	106/119 (48)/(54)
HD2-24	41-3/8" (1050)	18-1/8" (460)	20-1/2" (520))	16" (406)	106/119 (48)/(54)
HD2-30	41-3/8" (1050)	18-1/8" (460)	20-1/2" (520)	16" (406)	119/132 (54)/(60)
HD2-25/ HD2-31 HD2-36	46-1/2" (1180)	19-5/8" (500)	21-5/8" (550)	18" (456)	141/156 (64)/(71)
HD2-42	46-1/2" (1180)	19-5/8" (500)	21-5/8" (550)	18" (456)	141/156 (64)/(71)
HD2-43 HD2-48	54-1/2" (1185)	22" (560)	24" (610)	19-1/2" (496)	171/187 (78)/(85)
HD2-60/ HD2-61	54-1/2" (1185)	22" (560)	24" (610)	19-1/2" (496)	171/187 (78)/(85)

Specifications

Model		HD2-18	HD2-24	HD2-25	HD2-30	HD2-31	HD2-36	HD2-42	HD2-43	HD2-48	HD2-60	HD2-61	
Power supply	V-Ph-Hz	208/230V 1Ph 60Hz	208/230V 1Ph 60Hz	208/230V 1Ph 60Hz	208/230V 1Ph 60Hz	208/230V 1Ph 60Hz	208/230V 1Ph 60Hz	208/230V 1Ph 60Hz	208/230V 1Ph 60Hz	208/230V 1Ph 60Hz	208/230V 1Ph 60Hz	208/230V 1Ph 60Hz	
Indoor Motor	Type	PSC 3-speed Motor	PSC 3-speed Motor	PSC 3 -speed motor	PSC 3-speed Motor	PSC 3 -speed motor	PSC 3-speed Motor	PSC 3-speed Motor	PSC 3-speed motor	PSC 3-speed Motor	PSC 3-speed Motor	DC motor	
	H. power	HP	1/8	1/5	1/5	1/4	1/4	1/2	1/2	1/2	1/2	3/4	3/4
	Rated current	A	0.69	0.96	0.96	1.4	1.4	1.66	1.77	1.77	2.08	2.76	2.44
	Capacitor	uF	6	6	6	10	10	10	10	10	20	20	/
	Speed (hi/mi/lo)	RPM	1075	1075	1075	1075	1075	1075	1075	1075	1075	1075	/
Blower Wheel	Diameter	inch	10-3/4	10-3/4	10-3/4	10-1/4	10-3/4	10-3/4	10-3/4	10-3/4	10-3/4	10-3/4	10-3/4
	Width	inch	8	8	10-1/4	9-3/16	10-1/4	10-1/4	10-1/4	10-1/4	10-1/4	10-1/4	10-1/4
Indoor sound level	dB(A)	42/39/35	48/47/42	46/45/43	48/47/45	46/45/43	47/46/44	51/50/47	51/50/47	54/52/49	50/49/47	50/49/47	
Dimen- sions	Body (WxHxD)	inch	18-1/8"x 41-3/8"x 20-1/2"	18-1/8"x 41-3/8"x 20-1/2"	19-5/8x 46-1/2x 21-5/8	18-1/8"x 41-3/8"x 20-1/2"	19-5/8x4 6-1/2x 21-5/8	19-5/8"x 46-1/2"x 21-5/8"	19-5/8"x 46-1/2"x 21-5/8"	22x 54-1/2x 24	22"x 54-1/2"x 24"	22"x 54-1/2"x 24"	22x 54-1/2x 24
	Packing (WxHxD)	inch	21"x 43-1/2"x 22-7/8"	21"x 43-1/2"x 22-7/8"	22-1/2x 487/8x 24	21"x 43-1/2"x 22-7/8"	21/2x4 8-7/8x 24	22-1/2"x 48-7/8"x 24"	22-1/2"x 48-7/8"x 24"	25x 56-5/8x 26-3/8	25"x 56-5/8"x 26-3/8"	25"x 56-5/8"x 26-3/8"	25x 56-5/8x 26-3/8
	Net/Shipping	lbs	106/119	106/119	136/152	119/132	136/152	141/156	141/156	171/187	171/187	171/187	171/187
Refrig. piping	Liquid/ Gas side	inch	3/8 / 3/4	3/8 / 3/4	3/8"-3/4"	3/8 / 3/4	3/8"-3/4"	3/8 / 3/4	3/8 / 3/4	3/8"-7/8"	3/8 / 7/8	3/8 / 7/8	3/8"-7/8"

Blower Performance

Model Number	Motor Speed	CFM(L/S)(Watts)										
		External Static Pressure-Inches W.C. [kPa]										
		0[0]	0.1[0.2]	0.16[0.4]	0.2[0.5]	0.3[0.7]	0.4[1.0]	0.5[1.2]	0.6[1.5]	0.7[1.7]	0.8[2.0]	
18	Low	CFM	583	537	509	489	436	350	293	-	-	-
		RPM	449	536	584	627	684	735	786	-	-	-
		Watts	121	119	118	117	113	108	105	-	-	-
		Amps	0.62	0.62	0.62	0.62	0.62	0.61	0.6	-	-	-
	Medium	CFM	699	653	626	608	560	499	411	-	-	-
		RPM	525	587	619	645	720	777	819	-	-	-
		Watts	145	143	142	141	139	136	130	-	-	-
		Amps	0.69	0.69	0.68	0.68	0.67	0.67	0.63	-	-	-
	High	CFM	891	846	821	802	759	708	644	570	503	405
		RPM	649	693	720	753	787	831	903	916	949	981
		Watts	258	255	253	251	249	245	239	233	223	216
		Amps	1.21	1.21	1.2	1.2	1.2	1.19	1.18	1.16	1.14	1.12
24/25	Low	CFM	665	656	644	630	597	557	507	-	-	-
		RPM	528	591	630	650	728	790	840	-	-	-
		Watts	171	170	168	166	162	156	149.2	-	-	-
		Amps	0.79	0.79	0.79	0.79	0.78	0.76	0.75	-	-	-
	Medium	CFM	834	822	814	811	773	733	680	-	-	-
		RPM	658	701	730	743	790	841	888	-	-	-
		Watts	219	217	216	216	212	209	205	-	-	-
		Amps	0.96	0.96	0.95	0.95	0.94	0.93	0.92	-	-	-
	High	CFM	962	935	925	924	910	869	815	741	644	524
		RPM	741	769	785	802	837	877	919	956	986	1014
		Watts	284	281	279	277	275	271	265	258	248	238
		Amps	1.25	1.24	1.23	1.23	1.22	1.21	1.19	1.17	1.15	1.13

Blower Performance

Model Number	Motor Speed	CFM(L/S)(Watts)										
		External Static Pressure-Inches W.C. [kPa]										
		0[0]	0.1[.02]	0.16[.04]	0.2[.05]	0.3[.07]	0.4[.10]	0.5[.12]	0.6[.15]	0.7[.17]	0.8[.20]	
30/31	Low	CFM	962	913	886	870	813	750	690	-	-	-
		RPM	729	754	798	803	858	873	902	-	-	-
		Watts	315	304	298	292	280	269	258	-	-	-
		Amps	1.39	1.35	1.32	1.3	1.26	1.22	1.19	-	-	-
	Medium	CFM	1094	1043	1012	988	927	861	788	-	-	-
		RPM	809	845	859	885	911	932	954	-	-	-
		Watts	334	325	319	315	303	290	279	-	-	-
		Amps	1.46	1.43	1.4	1.38	1.35	1.3	1.26	-	-	-
	High	CFM	1374	1311	1268	1240	1164	1084	996	910	828	744
		RPM	910	937	947	954	972	989	1004	1018	1033	1043
		Watts	440	427	419	413	398	381	366	352	340	331
		Amps	1.94	1.9	1.86	1.84	1.79	1.74	1.68	1.63	1.6	1.56
36	Low	CFM	1129	1088	1061	1040	988	941	819	-	-	-
		RPM	642	675	706	732	771	817	853	-	-	-
		Watts	322	312	306	301	289	269	254	-	-	-
		Amps	1.54	1.52	1.51	1.5	1.47	1.42	1.39	-	-	-
	Medium	CFM	1317	1268	1237	1217	1157	1111	1027	-	-	-
		RPM	776	810	841	874	905	935	966	-	-	-
		Watts	360	354	348	345	335	323	309	-	-	-
		Amps	1.69	1.67	1.66	1.65	1.63	1.6	1.57	-	-	-
	High	CFM	1643	1581	1544	1518	1446	1356	1261	1123	915	812
		RPM	868	883	895	906	931	955	978	1013	1028	1050
		Watts	463	451	443	438	429	415	401	371	356	343
		Amps	2.22	2.2	2.18	2.17	2.14	2.12	2.09	2.03	1.99	1.96
42/43	Low	CFM	1239	1203	1178	1161	1117	1070	1000	-	-	-
		RPM	738	775	797	808	844	872	905	-	-	-
		Watts	396	385	376	371	360	345	327	-	-	-
		Amps	1.73	1.68	1.64	1.62	1.57	1.52	1.44	-	-	-
	Medium	CFM	1480	1431	1399	1379	1319	1259	1187	-	-	-
		RPM	843	865	882	893	915	937	959	-	-	-
		Watts	430	416	407	401	388	375	359	-	-	-
		Amps	1.87	1.81	1.77	1.75	1.69	1.63	1.57	-	-	-
	High	CFM	1738	1682	1639	1618	1548	1477	1378	1286	1042	908
		RPM	921	941	949	955	970	985	1002	1016	1042	1059
		Watts	508	493	486	478	460	445	431	412	373	354
		Amps	2.22	2.15	2.12	2.08	2.01	1.94	1.89	1.81	1.65	1.58
48	Low	CFM	1471	1427	1395	1374	1316	1247	1180	-	-	-
		RPM	694	732	753	769	803	833	864	-	-	-
		Watts	381	376	372	370	364	357	349	-	-	-
		Amps	1.66	1.64	1.63	1.62	1.6	1.58	1.55	-	-	-
	Medium	CFM	1729	1678	1646	1625	1558	1491	1402	-	-	-
		RPM	790	817	833	845	876	898	920	-	-	-
		Watts	485	477	473	470	460	451	240	-	-	-
		Amps	2.14	2.12	2.09	2.08	2.06	2.03	1.99	-	-	-
	High	CFM	2045	1992	1951	1928	1847	1763	1677	1563	1450	1317
		RPM	895	920	932	938	956	972	987	1002	1015	1030
		Watts	641	627	617	612	596	582	566	546	528	507
		Amps	2.86	2.82	2.8	2.78	2.73	2.68	2.64	2.57	2.52	2.45
60	Low	CFM	1786	1740	1709	1688	1630	1562	1489	-	-	-
		RPM	830	843	849	856	890	921	942	-	-	-
		Watts	584	569	560	552	536	516	497	-	-	-
		Amps	2.64	2.59	2.55	2.54	2.58	2.42	2.37	-	-	-
	Medium	CFM	2140	2071	2039	2006	1932	1799	1677	-	-	-
		RPM	917	930	938	943	957	970	990	-	-	-
		Watts	645	630	623	617	602	585	569	-	-	-
		Amps	2.87	2.81	2.78	2.76	2.71	2.65	2.59	-	-	-
	High	CFM	2357	2276	2225	2188	2100	2004	1902	1764	1554	1393
		RPM	964	976	982	990	1000	1012	1022	1032	1042	1063
		Watts	754	733	718	710	693	673	650	630	607	575
		Amps	3.34	3.27	3.22	3.19	3.12	3.05	2.98	2.91	2.83	2.71
61		CFM	2000	2000	2000	2000	2000	2000	2000	2000	2000	

Optional Accessories

Heat Kit Model	(kw) Electric Heat	MCA		Max. Fuse or Breaker (HACR type)		Ref. Air HAndler Use
		230V	208V	230V	208V	
CHE2-05(B)	5	21	18	30	30	18k, 24k, 30k, 36k, 42k, 48k, & 60k
CHE2-08(B)	7.5	32	28	50	50	18k, 24k, 30k, 36k, 42k, 48k, & 60k
CHE2-10(B)	10	42	36	60	60	18k, 24k, 30k, 36k, 42k, 48k, & 60k
CHE2-15B	15	64	56	30+60	30+60	36k, 42k, 48k, & 60k
CHE2-20B	20	84	72	60+60	60+60	36k, 42k, 48k, & 60k

(B) Circuit Breaker Option

Permanent washable filter

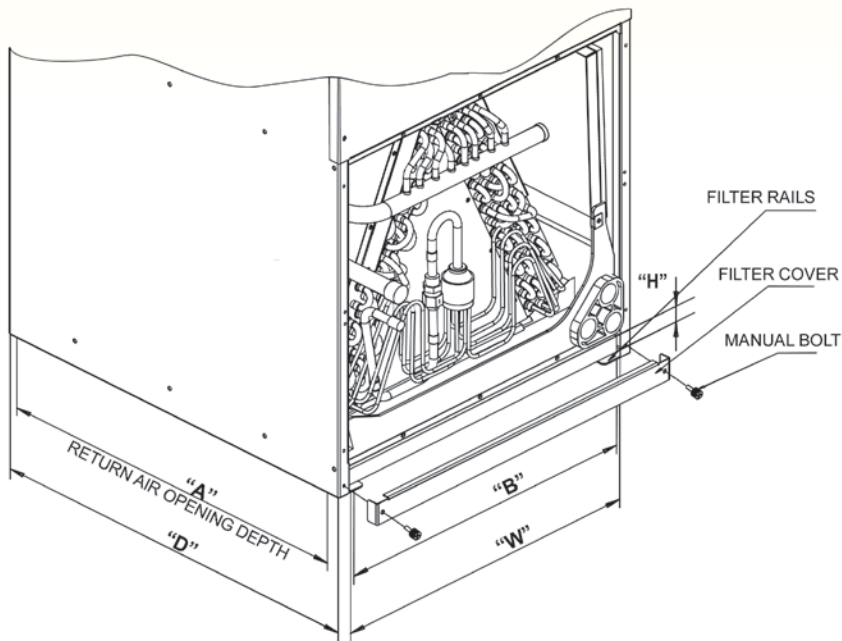

Model	Filter Size in (mm)	"W" in (mm)	"D" in (mm)	"H" in (mm)	Return width "A" in	Return width "B" in
18/24/30	16"x20" (406x508)	16.8" (426)	20.4" (518)	1" (25.4)	19.6"	14.8"
25/31/36/42	18"x20" (457x508)	18.3" (466)	21.6" (548)	1" (25.4)	20.8"	16.3"
43/48/60/61	20"x22" (508/559)	20.7" (526)	23.9" (608)	1" (25.4)	23"	18.8"



ComfortStar®
 12201 N.W. 107th Avenue
 Medley, FL 33178

toll free: 1-866-524-9898 • fax: 305-500-9896
 e-mail: info@comfortstarusa.com • www.comfortstarusa.com